



Program summary

WORK SUPPORTS

operating pressure up to 500 bar

single and double acting

4 different body types

3 types of operation

**maximum load force
from 3 to 102 kN**



**maximum plunger stroke
from 6 to 20 mm**

metallic wiper edge



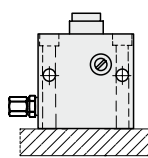
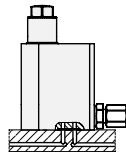
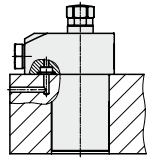
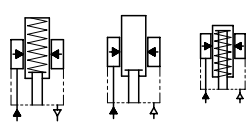
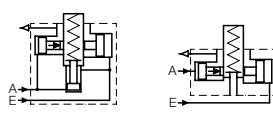
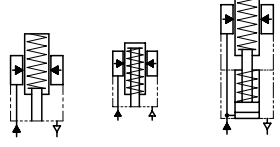

Program summary WORK SUPPORTS

Body design		Block-type						Top flange type		
Max. operating pressure		500 bar			500 / 400 bar			500 bar		
										
Data sheet		B 1.921			B 1.930			B 1.9503		
Hydraulic connection		pipe thread and drilled channels						pipe thread and drilled channels		
										
Functioning		single acting			double acting			single acting		
Off-position a = extended e = retracted		a a e			e a			a e e		
Hydraulic symbols										
Support plunger operation F = spring force H + F = hydraulics + spring force P = pneumatics		F P P			H + F F			F P H + F		
A = contact control, pneumatic S = positive air press. connection possible		-			-			S S S		
Position control, pneumatic		-			●			-		
Self-locking, hydraulically operated		-			●			-		
Recommended minimum pressure		100 bar			100 bar			100 bar		
Seals / wipers		NBR / NBR			FKM / FKM			NBR / FKM		
Metallic wiper edge		-			-			●		
Max. operating temperature		+80 °C			+150 °C			+80 °C		
Support plunger - diameter	mm	16	20	35	16	25	40	20	32	50
Support plunger - stroke	mm	6	8	10	8	12	20	12	16	20
Adm. load force (1)	kN	7	12.5	28	8	20	40	16.8	42	102
Max. flow rate	cm³/s	-	-	-	25	25	25	25	35	100
Spring contact force (2)	N	8...10	13.5...17	19.2...24	15...22	23...50	55...110	15...25	30...60	50...100
Pneumatic contact force(3)	N/bar	20.1	31.4	96.2	-	-	-	31	80	196
Elastic deformation (1)	µm/kN	3.6	1.7	1.3	0.7	1.5	1.0	4.5	2.8	1.8
Body cross section or external thread	mm	60x35	65x45	85x63	70x48	85x63	140x105	70x50	85x63	125x95

Legend: ● Series
○ Option
- not available

(1) at maximum operating pressure
(2) depending on the support plunger stroke
(3) for versions with spring return, the pneumatic contact force will be reduced by the spring return force

Round body with external thread

Threaded-body type

500 bar

500 bar

500 bar

500 bar

350 bar

500 bar

500 bar



B 1.914

B 1.900

B 1.910

B 1.911

B 1.9405

B 1.9401

B 1.9402

pipe thread and drilled channels

pipe thread - at the side or at the bottom

pipe thread - at the side

drilled channels

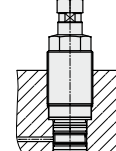
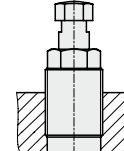
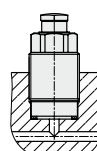
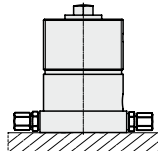
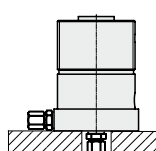
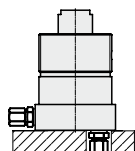
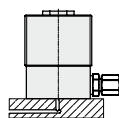

single acting

single acting

single acting

double acting

single acting

single acting

double acting

e

a

e

e

e

a

e

e

a

e

e

e

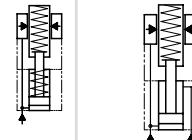
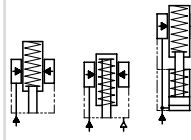
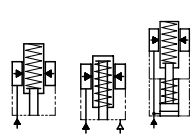
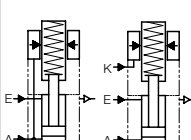
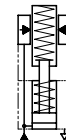
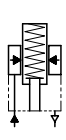
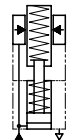

H + F

F

H + F

H + F

F

P

H + F

F

P

H + F

H + F

S

S

S

S

-

S

-

-

S

-

-

-

-

-

-

-

-

-

-

-

-

-

100 bar

100 bar

100 bar

100 bar

100 bar

100 bar

100 bar

NBR / FKM

NBR / FKM

NBR / FKM

NBR / FKM

NBR / FKM

NBR / FKM

NBR / FKM

●

●

●

●

●

●

●

+80 °C

+80 °C

+80 °C

+80 °C

+80 °C

+80 °C

+80 °C

32

32

40

40

40

16

16

16

12

16

18

18

18

6.5

8 or 15

8 or 15

20

32

48

48

48

4

6.5 or 9.5

6.5 or 9.5

35

-

70

25

25

25

25

30...60

10...90

60...100

50...100

15...25

7...33

10...33

-

-

-

-

20

20

-

1.3

1

1

1

3

6.5 kN: 3.5
9.5 kN: 4

4

M68x2

M68x2

M78x2

M78x2

M78x2

M26x1.5

M30x1.5

M30x1.5

Threaded-body type

500 bar



B 1.942

500 bar



B 1.943

500 bar



B 1.944

500 bar



B 1.9501

drilled channels

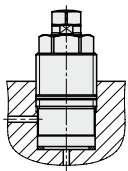

single acting

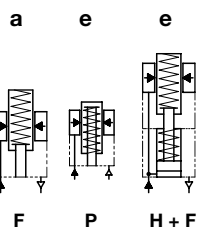

S

-

-

100 bar

NBR / FKM

●

+80 °C

20

10

15

25

20...32

31

2.7

M40x1.5

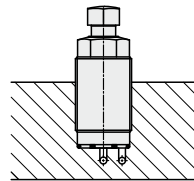

single acting

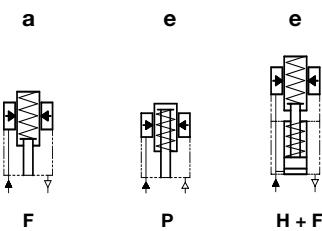

○ A + S

-

-

100 bar

NBR / FKM

●

+70 °C

16

8 or 15

6.5

10...23

20

3.5

M30x1.5

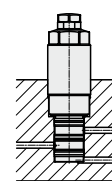

double acting

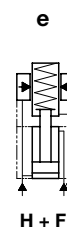

○ A + S

-

-

100 bar

NBR / FKM

●

+70 °C

16

8

6.5

10...13

-

3.5

M30x1.5

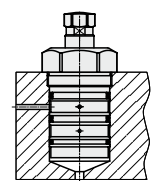

single acting

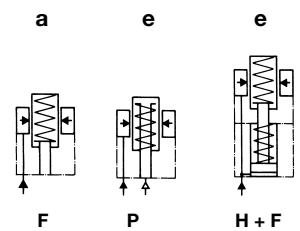

S

-

-

100 bar

NBR / FKM

●

+100 °C

20

12

16.8

25

15...25

31

4

M45x1.5



Threaded-body type

70 bar



B 1.9470

70 bar



B 1.9471

70 bar



B 1.9472

drilled channels

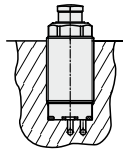

single acting

e

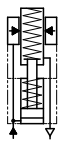

H + F

S

-

-

25 bar

NBR / FKM

●

+70 °C

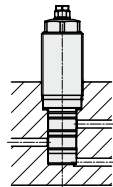

double acting

e



H + F

S

-

-

25 bar

NBR / FKM

●

+70 °C

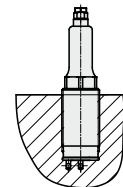

single + double acting

e

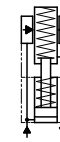

H + F

e

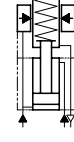

H + F

S

-

-

25 bar

NBR / FKM

●

+70 °C

10	12	15	16	10	12	15	16	10
6.5	8	8	10	6.5	8	8	10	6.5
3	4	5.5	10	3	4	5.5	10	3
● sharp-edged orifice				● sharp-edged orifice				● sharp-edged orifice
3.7...9.5	7...12	9.7...14.8	8.5...14.8	3.7...9.5	7...12	9.7...14.8	8.5...14.8	3.7...9.5
-				-				-
9	6	6	3.5	9	8	7	5	see data sheet
M26x1.5	M30x1.5	M36x1.5	M45x1.5	M26x1.5	M30x1.5	M36x1.5	M45 x1.5	M26x1.5



Types of operation

Spring force

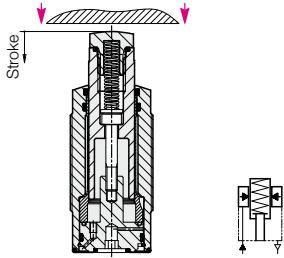

Off-position: Support plunger extended

The support plunger is pushed back when inserting the workpiece, the spring force has to be overcome.

The support plunger will be locked by hydraulic pressure and can compensate forces in axial direction.

After unclamping, the support plunger still remains in contact with the workpiece by spring force, until the workpiece will be unloaded from the fixture.

Advantages

Process-safe when loading and unloading workpieces in axial direction that are not too light (see figure above).

Functional safety independent of the flow rate.

Application

Hydraulic work supports are used to provide a self-adjusting rest for workpieces and avoid their vibration and deflection under machining loads.

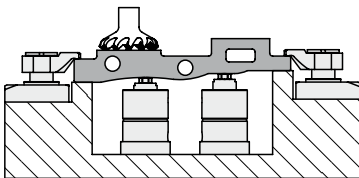

Single or double acting

To reduce the dimensions and the expenses for the control, most of the work supports are single acting with spring return of the support plunger.

Double-acting elements offer the advantage that the support plunger can be returned to the off-position within a precisely defined time.

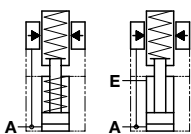

A: Extending and locking
E: Retracting and unlocking

Pneumatic

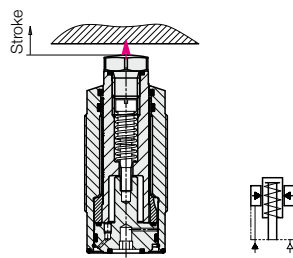

Off-position: Support plunger retracted

The support plunger contacts the workpiece by air pressure. The contact force is proportional to the air pressure less spring force.

The support plunger will be locked by hydraulic pressure and can compensate forces in axial direction.

For retraction, hydraulic and air pressure will be released. The support plunger retracts by spring force relatively slowly to its off-position.

Advantages

Unimpeded workpiece loading from all directions.

The contact pressure is at the same time the positive air pressure connection.

Function with locking bush

In the body of the work support a thin-walled locking bush is integrated, which locks cylindrically around a movable support plunger when pressurising the element with hydraulic oil.

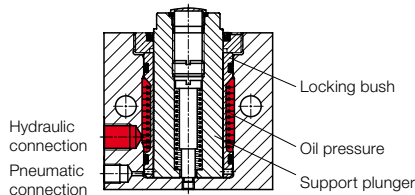

Function with locking piston

In the body of the work supports an additional locking piston is installed that locks a movable support plunger when pressurising the element.

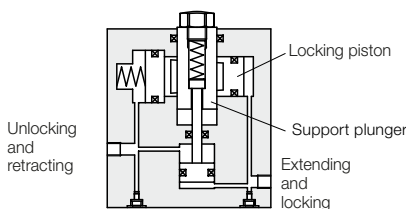

Self-locking

After depressurising, the support plunger remains locked. For unlocking, a second hydraulic port must be pressurised. The element can only be operated in the double-acting mode.

Hydraulic and spring force

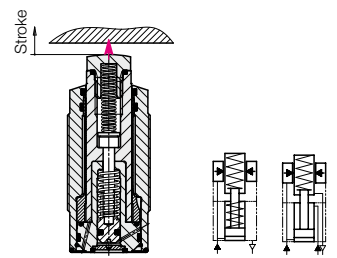

Off-position: Support plunger retracted

The support plunger is extended by a hydraulically pressurised small piston and contacts the workpiece with spring force.

The support plunger will be locked by increasing hydraulic pressure and can compensate forces in axial direction.

For retracting, hydraulic pressure will be released. The small piston retracts relatively slowly by spring force to its off-position and also retracts the support plunger.

In the case of double-acting work supports, the support plungers is retracted by the pull force of the piston.

Advantages

Unimpeded workpiece loading from all directions.

Double acting:

The support plunger is retracted reliably in a very short time.

Adm. load force

The admissible load is valid for static and dynamic load. Machining forces can generate vibrations, whose amplitude exceeds far an average value, and this can cause yielding of the support plunger.

Recommendation: Increase the safety factor, the number of work supports or the operating pressure.

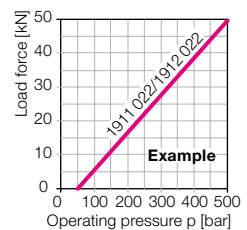

Elastic deformation

Work supports have such as other steel components an elastic behaviour, i.e. they yield in case of load.

The below diagram shows the elastic deformation of a work support with load.

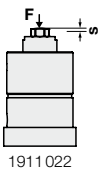
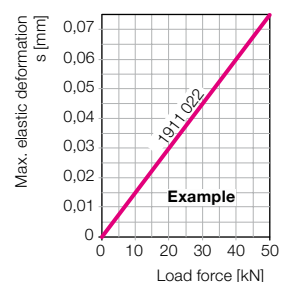



Contact force

The workpiece must not be deformed by the contact of the support plunger. Therefore, the contact is made with spring force or pneumatically. Depending on the size, the spring forces are between 4 and 100 N. With hydraulically extendable work supports, the contact force is the smallest, when the distance between the contact bolt and the workpiece is the largest before getting in contact.

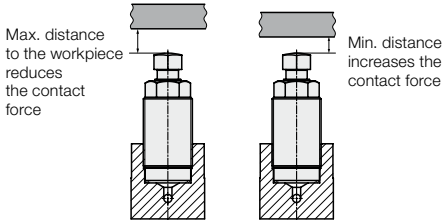

With pneumatic operation, the contact force can be precisely adapted by a pneumatic pressure reducing valve. The pneumatic connection serves at the same time as a connection for positive air pressure protection

Position monitoring

Pneumatic position monitoring of the support plunger is only possible with self-locking work supports (B 1.930).

Pneumatic contact control

The threaded-body work supports as per data sheet B 1.943 and B 1.944 can optionally be supplied with a sensor bore in the hardened contact bolt.

If the contact bolt is in contact with the workpiece, the air flow is interrupted.

A pneumatic flow meter with an adjustable limit switch then signals the contact of the support plungers.

Requirements:

- The contact surface at the workpiece is square to the axis of the work support.
- The contact surface is machined.
- The air is free of oil and water.

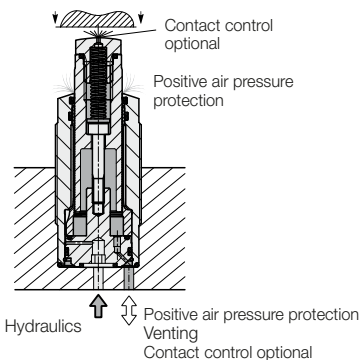

Air bleeding

Air in the oil can considerably prolong the clamping time. Work supports require only a minimum oil volume for their operation.

Since the hydraulic oil in the connecting line is nearly not moved, careful bleeding is required. If bleeding screws are not available, in the case of drilled channels screw plugs should be provided at the highest and remotest point.

Attention! Bleed always at low pressure.

Metallic wiper edge and wiper

The metallic wiper protects the wiper underneath against hot swarf or high coolant pressure. Important! For dry machining, minimum quantity lubrication and in case of accumulation of very small swarf, the work supports should be regularly cleaned and lubricated.

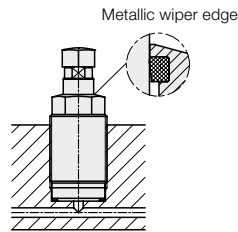

Venting of the spring area

All work supports, where the support plunger contacts the workpiece by spring force, must be vented (exception B 1.9401, B 1.9402, B 1.9405).

Especially when using coolants, a venting port is imperative to avoid that the coolants will be sucked in into the interior of the work support. In the case of non-compliance, troubles of functioning can occur.

Positive air pressure protection

The safest protection against penetration of liquids and particles is the connection of positive air pressure protection. This is possible for all work supports with vent port.

The air pressure must not exceed 0.2 bar.

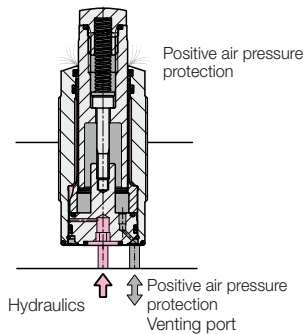

Maximum operating pressure

The work supports are designed for this pressure and can absorb the admissible load force. Recommendation: To ensure safe support of the workpieces even when vibrations occur, work supports should always be pressurised with the highest possible pressure.

Overload

If the forces indicated in the load force diagram are exceeded by more than 10%, the support plunger can yield.

Recommended minimum pressure

The minimum pressure already guarantees safe retention forces and should not be fallen below in clamping fixtures.

Admissible flow rate

The admissible flow rate for hydraulically extendable work supports can be taken from the data sheets.

If the flow rate is too high, the oil pressure increases so quickly that the support plunger will be locked before contacting the workpiece. In the case of this malfunction, the flow rate has to be throttled.

Throttle the flow rate

If the pump flow rate is higher than the sum of the connected admissible flow rates, throttling has to be effected in the supply line. Close the flow control valve until a satisfactory flow is ensured.

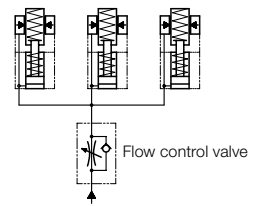

Problem:

The support plungers extend at different speeds and are locked too early.

Reasons:

- The holes in the fixture body are very long or of different lengths.
- The bore diameter is less than 4 mm.

As a result, the work supports receive different flow rates.

Remedy:

Throttle the work supports individually. We supply many work supports with sharp-edged orifices of the same diameter. Thus, the flow rate is evenly distributed.

Conditions:

The pressure should remain approximately constant during the extension time of the support plunger.

Sharp-edged orifices

The hydraulically extendable threaded-body work supports are supplied as standard or optionally with sharp-edged orifices.

Advantages:

- If several threaded-body work supports are connected to one supply line, the support plungers extend more evenly.
- The support plungers do not extend too quickly and do not bounce back from the workpiece.
- An additional external throttling of the flow rate is not required.

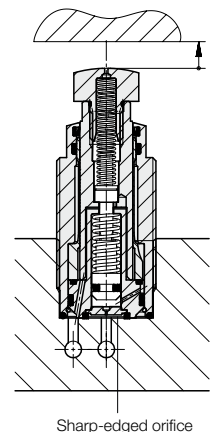



Contact bolts

Most of the work supports are delivered with a contact bolt in the support plunger. This contact bolt has a dome-head and hardened contact surface.

Attention ! Never use the work support without contact bolt, since penetrating dirt and liquids impede the function.

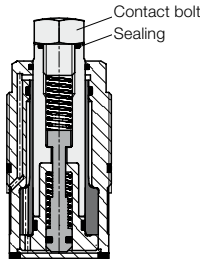

Special contact bolts

When using special contact bolts, the following has to be considered:

- The contact surface shall be hard and slightly dome-head so that it contacts safely the workpiece even in the case of uneven surfaces.
- A plane contact surface can only be realised with a swivel contact bolt. However, you have to reckon with higher elastic compliance with load since the swivel contact bolt will yield.
- A contact bolt with point or ribbing has the disadvantage that the points press into the workpiece with load which results in a higher elasticity. In addition, there will be a form fit so that side loads will be introduced into the support plunger, which is not admissible.
- The threaded stem must have the same length and interior contour as the original, which can be found on the data sheet. A drawing is available on demand.

Example:

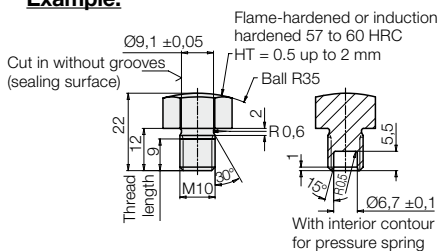

- Special contact bolts should weigh max. 0.1 kg to guarantee the function. For larger special contact bolts, please contact us.

Protection cap

The protection cap is designed to protect the wiper, if a strong coolant jet is directed at the support plunger or the metallic wiper edge. For some threaded-body work supports, protection caps are available as an accessory.

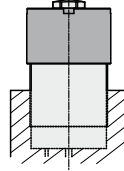

No side loads!

Work supports can only absorb forces in the direction of the support plunger axis.

If side loads are introduced into the support plunger, an exact position of the workpiece is no longer guaranteed.

Side loads arising during machining must be absorbed either by fixed workpiece supports or by horizontal stops.

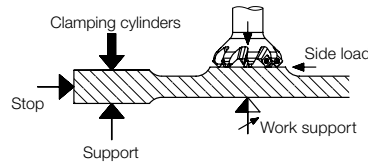

Work supports with side load absorption

Threaded-body work supports as per data sheet B 1.9472 can absorb side loads up to 0.3 kN:

Also, work supports with self-locking as per data sheet B 1.930 absorb side loads when a clamping element clamps directly onto the support plunger. The possible side load is 10 to 15% of the clamping force.

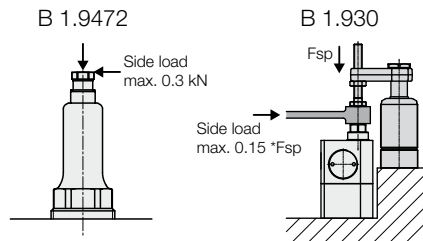

Mounting position

The work supports function in any mounting position. The technical data are only valid for the vertical mounting position. Due to the low spring forces, the weight of the support plunger and the contact bolt can influence the contact force and speed.

Römheld GmbH
Friedrichshütte
Römheldstraße 1-5
35321 Laubach, Germany
Tel.: +49 6405 89 0
Fax: +49 6405 89 211
E-mail: info@roemheld.de
www.roemheld-group.com